

Φ22

# 旋钮开关 H015

キースイッチ  
Rotary Switch



H015-2



H015-3

## ● 特点 Features

- \* 22mm安装孔径;
- \* 开关机构采用滑切机构, 能自行清除接点表面的积碳;
- \* 按钮接点最大可达3A/250VAC容量;
- \* 容易装置拆解的模组设计节省您的组装工时;
- \* 22mm取付穴径。
- \* スイッチ機構は滑り切り機構であり、自ら接点表面の炭素を除去することができる。
- \* ボタン接点の最大容量は3A/250VACとなる。
- \* 取り除きやすいモジュールデザインは、あなたの組立時間を節約する。
- \* Diameter of mounting recess: 22mm;
- \* The switching mechanism uses a sliding cutter which can automatically remove the carbon deposit from the surface of the contact;
- \* Max. capacity of button contact up to 3A/250VAC;
- \* Modular design easy for installation and disassembly saves assembling time;

## 符合标准

低压开关设备和控制设备总则  
IEC60947-1 : 2001 GB 14048.1-2006  
控制电路电器和开关元件  
IEC60947-5-1 : 20031 GB 14048.5-2008

## ● 关于选型 About selection

型号 Model	档位 Gears
H015	2

## ● 外形图 Dimensions

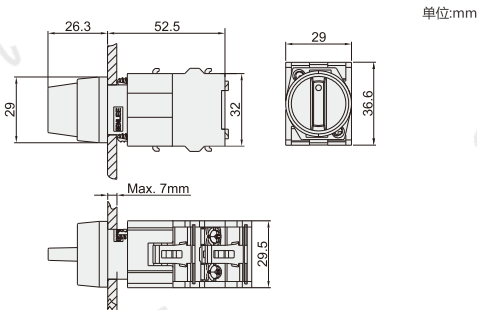

## ● 结构图 Structural Drawing

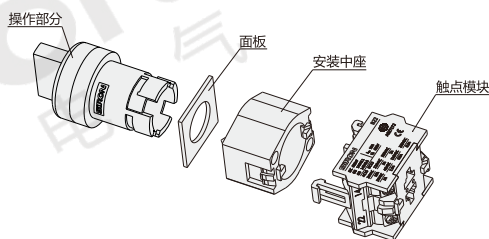

## ● 工作环境 Environment

工作温度(周围空气温度) Operating Temperature (Ambient Air Temperature)	-25°C ~ +55°C
储藏温度/工作湿度 Storage Temperature/Operating Humidity	-30°C ~ +85°C / ≤90%RH
安装类别 Mounting Category	Ⅲ类配电及控制水平 Class III power distribution and control level
安装极限高度 Mounting Height Limit	海拔2000m Altitude: 2000m
污染等级 Pollution Degree	3级 (能在有导电性污染, 或由于凝露使干燥的非导电性污染变成导电性污染的湿热环境下正常工作) Degree 3 (can operate normally in hot and humid environment that has conductive pollution or will have conductive pollution changed from dry non-conductive pollution due to condensation)

## ● 关联产品 Related Products



附件类/P.578  
Accessories/P.578



按钮盒/P.581  
Button Box/P.581



询问胜蓝  
0755-8886 0059 当日出货

分类  
classification

T 总线模块  
Bus module

T 端子台  
Terminal station

Y 电气控制  
Electrical control

X 连接电缆  
Connecting cable

H 电气配件  
Electrical fittings

P 开关电源  
Switching power supply

G 辅材配件  
Auxiliary fittings

F 气动附件  
Pneumatic accessories

● 技术参数 Technical Specification

接线端子螺钉拧紧力矩 Screw Tightening Torque of Terminal Block	≤0.8Nm	头部防护等级 Head Protection Class	IP 40				
操作力 Operating Force	操作力7~15N Operating Force: 7~15N	触点材料 Contact Material	银镍合金AgNi10 Silver nickel alloy (AgNi10)				
操作扭矩 Operating Torque	0.2Nm	接触电阻 Contact Resistance	≤50mΩ				
阻燃等级 Flame Retardant Rating	UL94-V0级 (与载流部件接触材料) UL94-V0 class (material in contact with current-carrying parts)	额定绝缘电阻 Rating Insulation Resistance	≥100mΩ(直流500V) ≥100mΩ (500VDC)				
相比漏电起痕指数 Comparative Tracking Index	CTI≥200V	使用类别 Usage Category	AC/DC				
电气间隙 Electric Clearance	>1.62mm	额定绝缘电压Ui Rating Insulation Voltage Ui	AC660V				
爬电距离 Creepage Distance	9.2mm两个导电部件间沿绝缘材料表面的最短距离 9.2mm - min. distance between two conductive parts on surface of insulation material	工频耐压 Power Frequency Withstand Voltage	AC2500V 1分钟				
耐冲击性 Impact Resistance	>3g, 冲击时间11ms, 半正弦波 ≥3g, Impact Time: 11ms, Half Sinusoid	约定自由空气发热电流Ith Free air heating current set Ith	10A				
抗震动性 Vibration Resistance	10g, 频率10~2000Hz, 振幅0.75mm 10g, Frequency: 10~2000Hz, Vibration Amplitude: 0.75mm	额定短时耐受电流Icw Rating Short-time Withstand Current Icw	1000A				
最高操作频率 Max. Operating Frequency	2400次/小时	弹跳时间 Bounce Time	3ms				
接线界面 Wiring Interface	接插式端子尺寸: 6.3×0.8mm硬线最大截面积2×2.5mm <sup>2</sup> 软线最大面积: 2×1.5mm <sup>2</sup> Connect terminal size: 6.3x0.8mm, the max cross-sectional area of hard-line: 2x2.5mm <sup>2</sup> the max area of cord-line: 2x1.5mm <sup>2</sup>						
机械寿命 Mechanical Life	≥300万次						
开关额定值 Switch Rating							
额定工作电压Ue Rating Operating Voltage Ue	24V	220V	380V	24V	48V	110V	220V
额定工作电流Ie Rating Operating Current Ie	10A	3A	2A	3A	1.5A	0.6A	0.3A
触点寿命 Contact Life	AC-15 100万次			DC-13 60万次			

● 安装尺寸 Mounting Dimension

面板开孔尺寸 Mounting hole

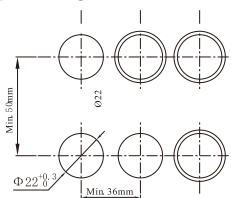

注: 以上为推荐最小安装尺寸, 密集安装时可根据情况适当减小安装距离, 但可能使得安装及接线困难。

Note: The above is the recommended minimum mounting dimension. In case of high density mounting, the mounting distance may be reduced appropriately according to the situation. However, the mounting and wiring may be hard.

● 端子构成 Terminal Structure

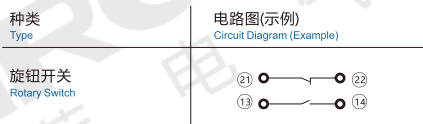

● 动作模式 Action Mode

