

内嵌式丝杆模组 (紧凑型) M313系列

内蔵式ねじ型モジュール
Built-in lead screw module

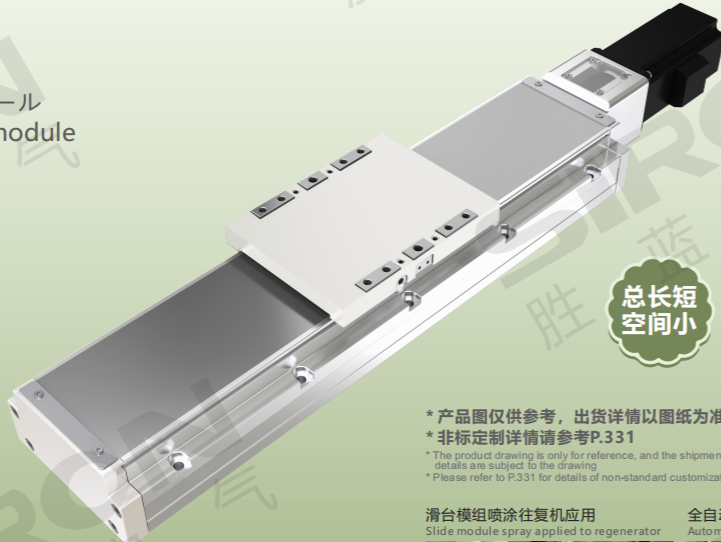

总长短
空间小

* 产品图仅供参考，出货详情以图纸为准
* 非标定制详情请参考P.331

* The product drawing is only for reference, and the shipment details are subject to the drawing
* Please refer to P.331 for details of non-standard customization

滑台模组喷涂往复式应用
Slide module spray applied to regenerator



全自动焊锡机应用
Automatic soldering machine application



最大行程 Maximum stroke 1250mm	最高速度 Maximum speed 1600mm/s	马达容量 Capacity of motor 400W	滚珠螺杆 Ball bearing screw Φ16mm
----------------------------------	-----------------------------------	-----------------------------------	-------------------------------------

关于选型 About selection

M31	3	5	50	BC	M	40	E	5
模组系列 Module series	本体代号 Type of body	导程 Lead	行程 Trip	马达位置 Position of motor	马达品牌 Brand of motor	马达功率 Power of motor	原点感应器 Origin inductor	端点极限感应器 End limit inductor
	3	5 5mm 10 10mm 20 20mm 32 32mm	50-1300mm 50mm间隔 行程50限定只能安装2组光电 Trip 50 limited only can install 2 groups of photoelectric 见行程表	BC 马达外露 Exposure of motor BM 马达下折 Under the motor off BL 马达左折 Motor left off BR 马达右折 Motor right off	M 三菱 Mitsubishi P 松下 Panasonic Y 安川 Yaskawa T 台达 Delta S 胜蓝 SIRON A 禾川 Grain of sichuan H 汇川 Kymmenne ST 步进 Step by step 带刹车在功率后边加字母“B”	40 400W 75 750W	外挂型 External hanging type C 马达侧 Side of motor D 反马达侧 Reverse side of motor E 无 NO	5 无 *若需感应器请单独选购 * Please buy a separate sensor if you need one

选型举例：M313-5-50-BC-M40B-E5为：M313系列，导程5mm，行程50，马达外露，三菱400W带刹车，无原点感应器，无极限感应器；注：若需其它样式，请咨询我司销售人员。
Selection example: M313-5-50-BC-M40B-E5 is M313 series, guide 5mm, stroke 50, motor exposed, Mitsubishi 400W with brake, no origin sensor, no limit sensor; Note: If you need other styles, please consult our sales staff.

原点感应器：选型行程50mm时的限制：①原点型极限需放置于不同侧，②滑座左右两侧均需安装感应片；
Origin sensor: the limit of selection stroke 50mm: (1) Origin type limit should be placed on different sides, (2) induction plates should be installed on both sides of the slide seat.

马达安装方式 Installation method

<p>BC 马达外露 BC motor exposed</p>	<p>BM 马达下折 BM motor dips</p>	<p>BL 马达左折 BL motor left fold</p>	<p>BR 马达右折 BR motor fold right</p>
--	---	--	---

注：最大负载：30kg；本体宽度：54mm；

规格参数 Specification

项目 Project		规范 Specification				
规格 Specification	位置重复精度(mm) Repeatability(mm)	±0.01				
	螺杆导程(mm) Ball screw lead(mm)	5	10	20	32	
	最高速度(mm/s) Maximum speed(mm/s)	250	500	1000	1600	
	最大可搬重量(kg) Maximum payload(kg)	水平使用 Horizontal	110	88	40	30
		垂直使用 Vertical	33	22	10	8
	定格推力(N) Rated thrust(N)	1388	694	347	218	
标准行程(mm) Stroke pitch(mm)	50-1250mm/50间隔					
部品 Parts	Ac伺服马达容量(w) AC Servo motor output(w)	400				
	可配步进电机 Can be equipped with stepping motor	86				
	滚珠螺杆外径(mm) Ball screw(mm)	C7 Φ16				
	联轴器(mm) Coupling(mm)	10×14				
	原点感应器 Home sensor	外挂 Outside	K017-A6			

注：行程超过850mm，会产生螺杆偏摆，此时请将速度调降，马达加减设定0.2秒，使用Panasonic200马达时，马达轴心为Φ11其它厂牌，马达轴心为Φ14；

容许负载力距表 Allowable overhang

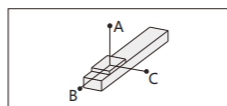

水平安装 Horizontal installation		A	B	C
Φ螺径 5 Lead	60kg	1560	153	237
	80kg	890	81	126
	110kg	550	53	82
Φ螺径 10 Lead	30kg	1730	286	412
	50kg	839	136	196
	88kg	541	86	124
Φ螺径 20 Lead	10kg	1213	403	493
	22kg	800	264	323
	40kg	592	194	238
Φ螺径 32 Lead	15kg	1100	570	550
	25kg	620	330	320
	30kg	520	270	260

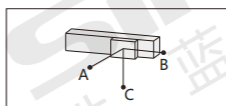

壁挂安装 Wall installation		A	B	C
Φ螺径 5 Lead	55kg	280	280	3300
	75kg	200	195	2400
	110kg	130	125	1550
Φ螺径 10 Lead	35kg	400	410	2500
	55kg	245	250	1550
	88kg	150	150	950
Φ螺径 20 Lead	12kg	900	1070	3000
	20kg	550	630	1800
	40kg	260	300	900
Φ螺径 32 Lead	15kg	440	570	1050
	30kg	210	270	520
	/	/	/	/

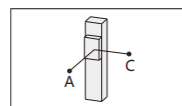

垂直安装 Vertical installation		A	C
Φ螺径 5 Lead	15kg	1200	120
	22kg	820	820
	33kg	550	550
Φ螺径 10 Lead	10kg	1600	1600
	14kg	1150	1150
	22kg	730	730
Φ螺径 20 Lead	7kg	1800	1800
	10kg	1250	1250
	/	/	/
Φ螺径 32 Lead	5kg	1600	1600
	8kg	1000	1000
	/	/	/

静态容许负载惯量 Static loading moment

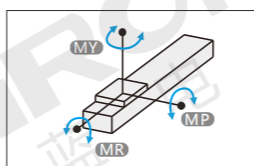

	N.m
MY	606
MP	606
MR	1168

力距表所表示的数据，代表重心符合型录规格的正常使用时，保证寿命为10000公里倒用使用无法套用标准规范，如有需求请咨询我司销售人员

搭配伺服马达一览表 Suitable motor brand

品牌 Brand	马达记号 The motor mark	刹车有无 Whether the brakes	马达容量 Motor capacity	电源电压 voltage	伺服马达型号 Motor model	驱动器型号 voltage
三菱 Mitsubishi	M	无刹车(水平仕样) No brakes (horizontal style)	400	220	HG-KR43	MR-J4-40A
		有刹车(垂直仕样) With brake (vertical style)	400	220	HG-KR43B	
松下 Panasonic	P	无刹车(水平仕样) No brakes (horizontal style)	400	220	MHMD042G1U	MBDHT2510
		有刹车(垂直仕样) With brake (vertical style)	400	220	MHMD042G1V	
台达 Delta	T	无刹车(水平仕样) No brakes (horizontal style)	400	220	ECMA-C20604ES	ASD-B20421-B
		有刹车(垂直仕样) With brake (vertical style)	400	220	ECMA-C20604FS	

感应器接线图

Inductor wiring diagram

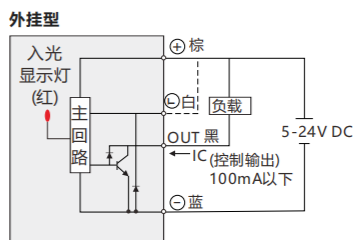

分类 classification

内嵌式丝杆型
Built-in lead screw type

内嵌式丝杆型
Built-in lead screw type

内嵌式推杆型
Built-in push-rod type

内嵌式皮带型
Built-in belt type

一般丝杆型
General screw type

一般皮带型
General belt type

无尘丝杆型
Dust free screw type

无尘皮带型
Dust free belt type

单轴滑台
Single axle slide table

直线电机模组
Linear motor module

内嵌式丝杆型
Built-in lead screw type

内嵌式丝杆型
Built-in lead screw type

内嵌式推杆型
Built-in push-rod type

内嵌式皮带型
Built-in belt type

一般丝杆型
General screw type

一般皮带型
General belt type

无尘丝杆型
Dust free screw type

无尘皮带型
Dust free belt type

单轴滑台
Single axle slide table

直线电机模组
Linear motor module

外形尺寸图 General dimension drawing

BC 马达外露

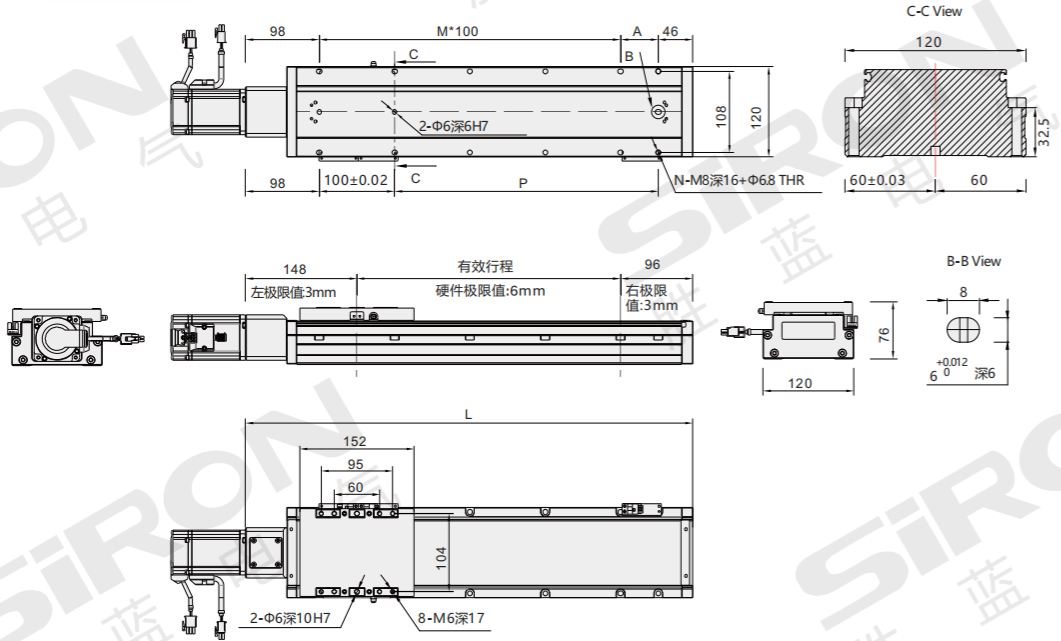

行程50和100时，因本体上锁定式固定孔会被滑座遮住，仅能使用4只螺丝固定，建议客户本体使用下锁式固定孔锁附。

	mm												
有效行程 Stroke	50	100	150	200	250	300	350	400	450	500	550	600	650
L	294	344	394	444	494	544	594	644	694	744	794	844	894
A	50	100	50	100	50	100	50	100	50	100	50	100	50
M	1	1	2	2	3	3	4	4	5	5	6	6	7
N	6	6	8	8	10	10	12	12	14	14	16	16	18
P	50	100	150	200	250	300	350	400	450	500	550	600	650
重量(kg)	5.05	5.40	5.75	6.10	6.45	6.80	7.15	7.50	7.85	8.20	8.55	8.90	9.25
有效行程 Stroke	700	750	800	850	900	950	1000	1050	1100	1150	1200	1250	1300
L	944	994	1044	1094	1144	1194	1244	1294	1344	1394	1444	1494	1544
A	100	50	100	50	100	50	100	50	100	50	100	50	100
M	7	8	8	9	9	10	10	11	11	12	12	13	13
N	18	20	20	22	22	24	24	26	26	28	28	30	30
P	700	750	800	850	900	950	1000	1050	1100	1150	1200	1250	1300
重量(kg)	9.60	9.95	10.30	10.65	11.00	11.35	11.70	12.05	12.40	12.75	13.10	13.45	13.80

分类
classification

内嵌式丝杆型
Built-in lead screw type

内嵌式丝杆型
Built-in lead screw type

内嵌式推杆型
Built-in push-rod type

内嵌式皮带型
Built-in belt type

一般丝杆型
General screw type

一般皮带型
General belt type

无尘丝杆型
Dust free screw type

无尘皮带型
Dust free belt type

单轴滑台
Single axle slide table

直线电机模组
Linear motor module

外形尺寸图 General dimension drawing

BM 马达下折

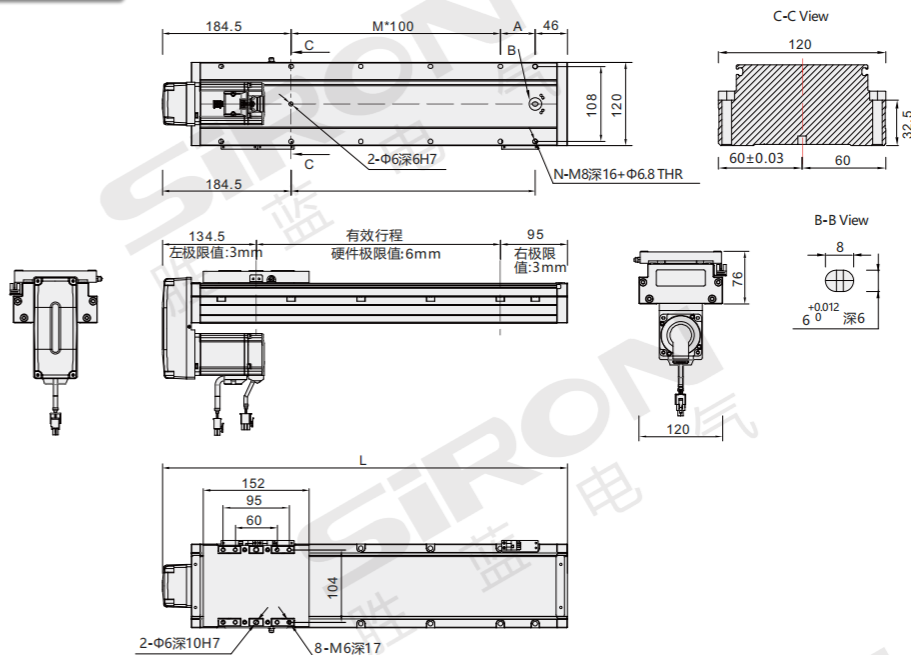

行程50和100时，因本体上锁定位固定孔会被滑座遮住，仅能使用4只螺丝固定，建议客户本体使用下锁式固定孔锁附。

mm

有效行程 Stroke	50	100	150	200	250	300	350	400	450	500	550	600	650
L	280.5	330.5	380.5	430.5	480.5	530.5	580.5	630.5	680.5	730.5	780.5	830.5	880.5
A	50	100	50	100	50	100	50	100	50	100	50	100	50
M	0	0	1	1	2	2	3	3	4	4	5	5	6
N	4	4	6	6	8	8	10	10	12	12	14	14	16
P	50	100	150	200	250	300	350	400	450	500	550	600	650
重量(kg)	5.25	5.60	5.95	6.30	6.65	7.00	7.35	7.70	8.05	8.40	8.75	9.10	9.45
有效行程 Stroke	700	750	800	850	900	950	1000	1050	1100	1150	1200	1250	1300
L	930.5	980.5	1030.5	1080.5	1130.5	1180.5	1230.5	1280.5	1330.5	1380.5	1430.5	1480.5	1530.5
A	100	50	100	50	100	50	100	50	100	50	100	50	100
M	6	7	7	8	8	9	9	10	10	11	11	12	12
N	16	18	18	20	20	22	22	24	24	26	26	28	28
P	700	750	800	850	900	950	1000	1050	1100	1150	1200	1250	1300
重量(kg)	9.80	10.15	10.85	11.20	11.55	11.90	12.25	12.60	12.95	13.30	13.65	14.00	14.35

注：马达下折时，若选用刹车马达，或是超出马达总长度限制时无法套用标准PIN孔，如有需求请咨询我司销售人员。

外形尺寸图 General dimension drawing

BL 马达左折

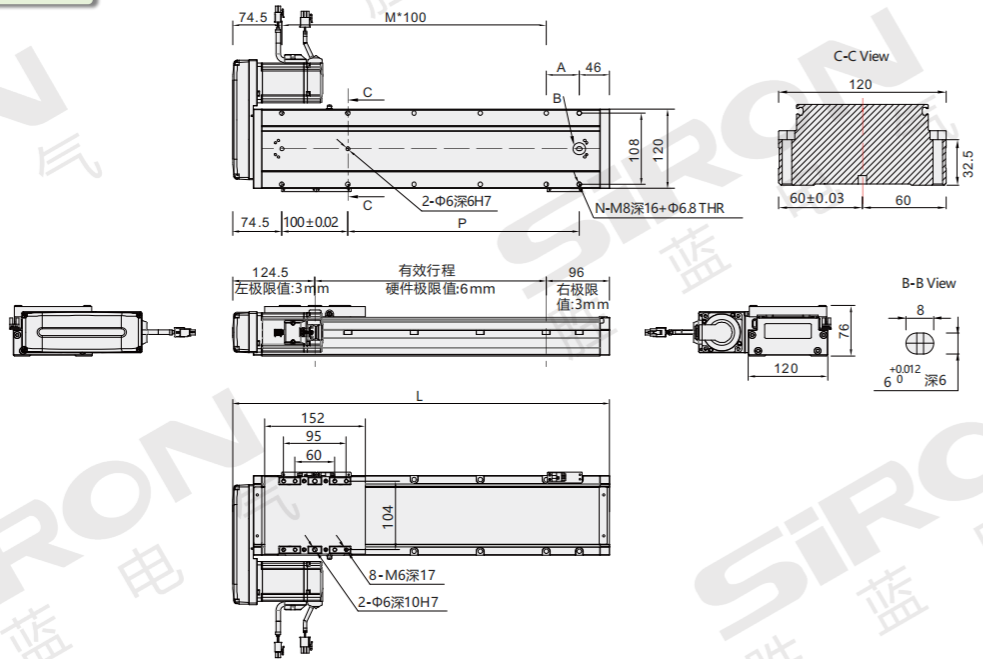

行程50时，因本体上锁定制固定孔会被滑座遮住，仅能使用4只螺丝固定，建议客户本体使用下锁式固定孔锁附。

有效行程 Stroke	50	100	150	200	250	300	350	400	450	500	550	600	650
L	270.5	320.5	370.5	420.5	470.5	520.5	570.5	620.5	670.5	720.5	770.5	820.5	870.5
A	50	100	50	100	50	100	50	100	50	100	50	100	50
M	1	1	2	2	3	3	4	4	5	5	6	6	7
N	6	6	8	8	10	10	12	12	14	14	16	16	18
P	50	100	150	200	250	300	350	400	450	500	550	600	650
重量(kg)	5.25	5.60	5.95	6.30	6.65	7.00	7.35	7.70	8.05	8.40	8.75	9.10	9.45

有效行程 Stroke	700	750	800	850	900	950	1000	1050	1100	1150	1200	1250	1300
L	920.5	970.5	1020.5	1070.5	1120.5	1170.5	1220.5	1270.5	1320.5	1370.5	1420.5	1470.5	1520.5
A	100	50	100	50	100	50	100	50	100	50	100	50	100
M	7	8	8	9	9	10	10	11	11	12	12	13	13
N	18	20	20	22	22	24	24	26	26	28	28	30	30
P	700	750	800	850	900	950	1000	1050	1100	1150	1200	1250	1300
重量(kg)	9.80	10.15	10.85	11.20	11.55	11.90	12.25	12.60	12.56	12.91	13.26	13.61	13.96

分类
classification

内嵌式丝杆型
Built-in lead screw type

内嵌式丝杆型
Built-in lead screw type

内嵌式推杆型
Built-in push-rod type

内嵌式皮带型
Built-in belt type

一般丝杆型
General screw type

一般皮带型
General belt type

无尘丝杆型
Dust free screw type

无尘皮带型
Dust free belt type

单轴滑台
Single axle slide table

直线电机模组
Linear motor module

外形尺寸图 General dimension drawing

BR 马达右折

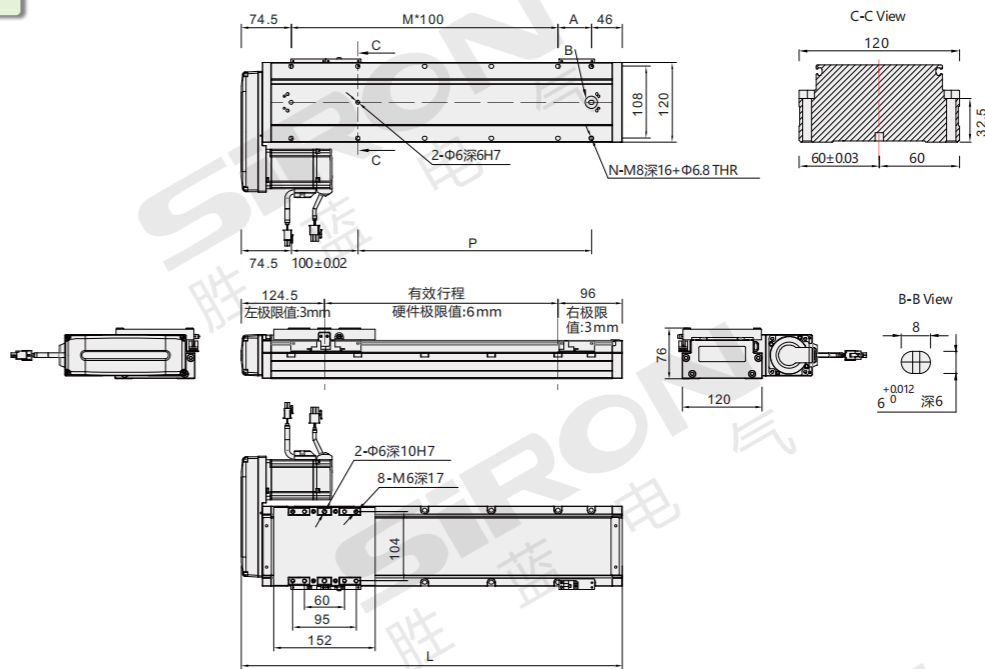

行程50和100时，因本体上锁定型固定孔会被滑座遮住，仅能使用4只螺丝固定，建议客户本体使用下锁式固定孔锁附。

mm

有效行程 Stroke	50	100	150	200	250	300	350	400	450	500	550	600	650
L	270.5	320.5	370.5	420.5	470.5	520.5	570.5	620.5	670.5	720.5	770.5	820.5	870.5
A	50	100	50	100	50	100	50	100	50	100	50	100	50
M	1	1	2	2	3	3	4	4	5	5	6	6	7
N	6	6	8	8	10	10	12	12	14	14	16	16	18
P	50	100	150	200	250	300	350	400	450	500	550	600	650
重量(kg)	5.25	5.60	5.95	6.30	6.65	7.00	7.35	7.70	8.05	8.40	8.75	9.10	9.45

有效行程 Stroke	700	750	800	850	900	950	1000	1050	1100	1150	1200	1250	1300
L	920.5	970.5	1020.5	1070.5	1120.5	1170.5	1220.5	1270.5	1320.5	1370.5	1420.5	1470.5	1520.5
A	100	50	100	50	100	50	100	50	100	50	100	50	100
M	7	8	8	9	9	10	10	11	11	12	12	13	13
N	18	20	20	22	22	24	24	26	26	28	28	30	30
P	700	750	800	850	900	950	1000	1050	1100	1150	1200	1250	1300
重量(kg)	9.80	10.15	10.85	11.20	11.55	11.90	12.25	12.60	12.95	13.30	13.65	14.00	14.35

注：马达下折时，若选用刹车马达，或是超出马达总长度限制时无法套用标准PIN孔，如有需求请咨询我司销售人员。